



<p><b>Asianda®</b></p>	<p>Shenzhen Yaxunda LCD Display Equipment Co., Ltd</p>
<p>Model no: YXD49P</p>	<p>version no: WA9</p>
<p>Quote (RMB)</p>	<p>PROTOTYPE::                      50PCS:                      100PCS:</p>
<p>Date</p>	<p><b>Note: This offer is one year with tax and freight not included</b></p>
<p><b>49-inch floor-mounted advertising machine</b></p>	
<p>Product Image</p>	
<p>Product size</p>	<p>1848*97*716 h * t * w (mm)</p>
<p>Aplication Pictures</p>	



<p><b>Product characteristics</b></p>	<p>3d digital filter noise reduction, line-by-line scanning, the screen is true and delicate;          Smart screen protection function, prevent Burns;          Various high definition signal interface, strong compatibility;          Intelligent backlight brightness control, improve the visual effect of image, save energy and save electricity;          The intelligent temperature control cooling / heating system ensures the machine to work stably in the best environment.</p>
<p><b>Playback system</b></p>	<p>Each playing area can be arranged and layered freely, and can be played on horizontal and vertical screens;          Screen Area Free Segmentation, composable picture, audio, video, web page, clock, date, caption, mixed material editing;          Support Program and broadcast table preview, real-time monitoring playback screen, multi-stage timing switch settings, automatic reset;          Different users can set different permissions;          Adopt distributed management, support remote or local control;          Support android phone or tablet terminal to play a list of programs, remote monitoring, timing switch function;          Screen brightness can be adjusted automatically according to the surrounding environment;          Supports a variety of general audio / Video, and office documents;          Support cable, Wifi, 4G network.</p>
<p><b>Product name</b></p>	<p><b>Specification parameter</b></p>
<p><b>Display screen</b></p>	<p>LCD: 49 Inch          Resolution: 1920 * 1080          Display Area: 1210 * 680          contrast: 4000:1          brightness: 450 CDM2          Angle: Horizontal / Vertical: 178          backlight: LED backlight</p> <p>TFT SCREEN RATIO: 16:9          Point Distance: 0.63 * 0.63          Response Time: 6ms</p>
<p><b>Motherboard scheme</b></p>	<p>MOTHERBOARD: RK3288 quad-core, 2.0          Ghz Ram: 2 GB          BUILT-IN STORAGE: EMMC 8G expandable 64G          operating system:</p>
<p><b>Android interface</b></p>	<p>POWER    DC 12V    AUDIO    USB    OTG    USB    TF/SIM    RJ45    UBOOT</p>

<b>Accessories</b>	Manual, remote control, warranty card, certificate of conformity, Power Cord	
<b>Product structure</b>	Product architect	Hardware shell + lacquer process + aluminum alloy border
	Installation mode	Floor type
	Protective Glass	4 mm toughened glass
	Weight	54kg
	Product size	1848*97*716 (mm)
	Packing size	1960*210*810 (mm)
<b>Operating parameter</b>	Brightness Control	
	Temperature	
	Working Environment	Working Temperature: 0 ° C to + 50 ° C working humidity: 5% to 90%
	Power supply	AC110~240V
	Power	80W

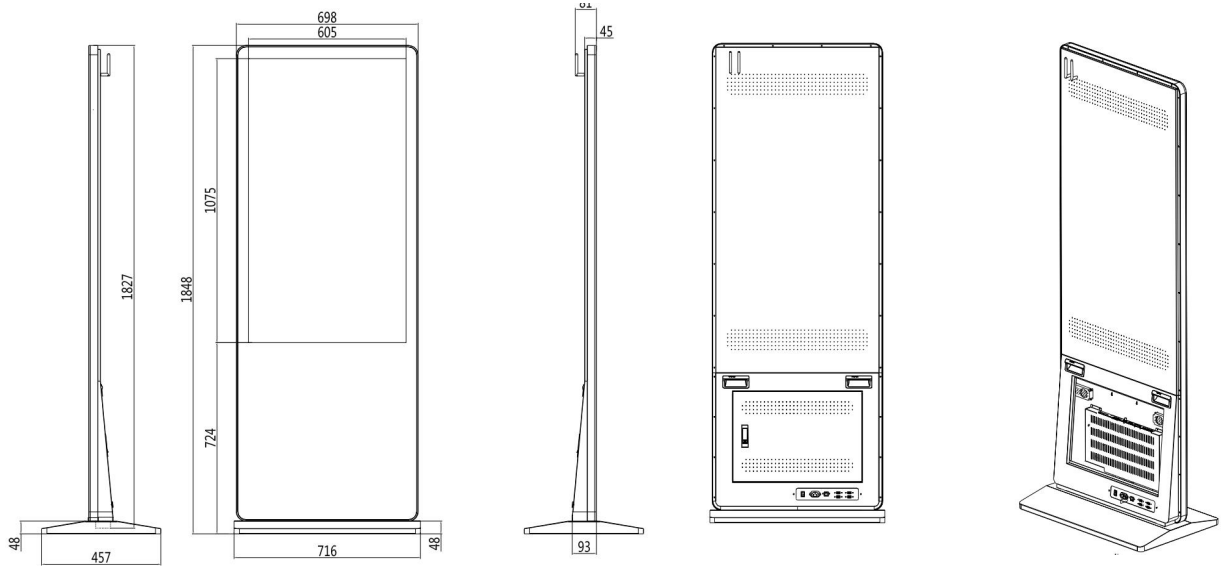
**Asianda®**

Shenzhen Yaxunda LCD Display Equipment Co., Ltd

Model no: YXD49P

version no: WA9

Quote (RMB)

PROTOTYPE::

50PCS:

100PCS:

Date

Note: This offer is one year with tax and freight not included

49-inch floor-mounted advertising machine-capacitive touch

Product Image

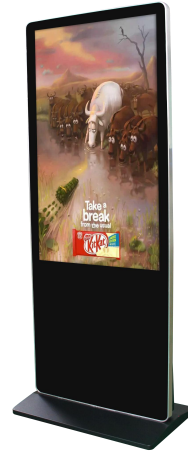

Product size

1848\*97\*716 h \* t \* w (mm)

Application Pictures

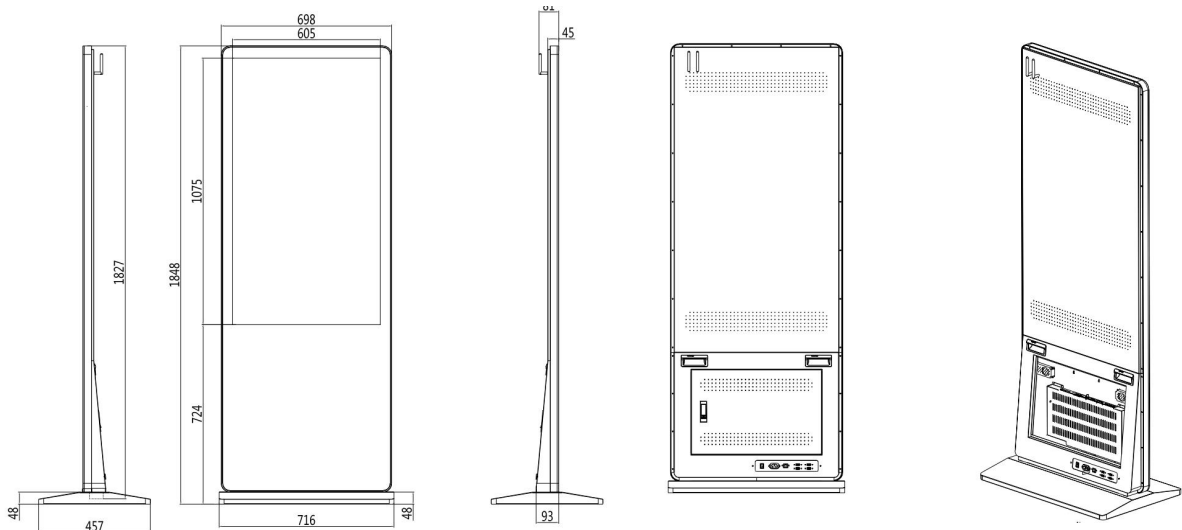

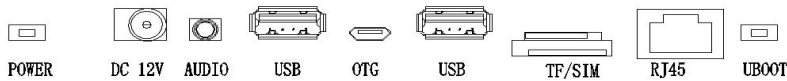
<b>Product characteristics</b>	<p>3d digital filter noise reduction, line-by-line scanning, the screen is true and delicate;</p> <p>Smart screen protection function, prevent Burns;</p> <p>Various high definition signal interface, strong compatibility;</p> <p>Intelligent backlight brightness control, improve the visual effect of image, save energy and save electricity;</p> <p>The intelligent temperature control cooling / heating system ensures the machine to work</p>	
<b>Playback system</b>	<p>Each playing area can be arranged and layered freely, and can be played on horizontal and vertical screens;</p> <p>Screen Area Free Segmentation, composable picture, audio, video, web page, clock, date, caption, mixed material editing;</p> <p>Support Program and broadcast table preview, real-time monitoring playback screen, multi-stage timing switch settings, automatic reset;</p> <p>Different users can set different permissions;</p> <p>Adopt distributed management, support remote or local control;</p> <p>Support android phone or tablet terminal to play a list of programs, remote monitoring, timing switch function;</p> <p>Screen brightness can be adjusted automatically according to the surrounding environment;</p> <p>Supports a variety of general audio / Video, and office documents;</p> <p>Support cable, Wifi, 4G network.</p>	
<b>Product name</b>	<b>Specification parameter</b>	
<b>Display screen</b>	<p>LCD: 49 Inch</p> <p>Resolution: 1920 * 1080</p> <p>Display Area: 1210 * 680</p> <p>contrast: 4000:1</p> <p>brightness: 450 CDM2</p> <p>Horizontal / Vertical: 178</p>	<p>TFT SCREEN RATIO: 16:9</p> <p>Point Distance: 0.63 * 0.63</p> <p>Response Time: 6ms</p> <p>Angle:</p>
<b>Touch screen</b>	<p>10 points high precision, G+G touch screen</p> <p>Transmission rate is 90 , resolution: 4096 * 4096</p> <p>Minimum Touch Body: Surround 3mm Response Speed: &amp; lt; 10ms</p> <p>Surface hardness: Mohs 7 scan rate: 50 scans / S</p> <p>Operating temperature: 0 ° C ~ 50 ° C,</p> <p>Durability: withstand more than 600,000,000 10-point touches</p> <p>Operating system: Windows 7 \ XP \ 2003 \ Linux, MacOS</p>	
<b>Motherboard scheme</b>	<p>MOTHERBOARD: RK3288 quad-core, 2.0</p> <p>2 GB</p> <p>BUILT-IN STORAGE: EMMC 8G expandable 64G</p>	<p>Ghz Ram:</p> <p>operating system: Android6.0</p>
<b>Android interface</b>	 <p>POWER    DC 12V    AUDIO    USB    OTG    USB    TF/SIM    RJ45    UB00T</p>	
<b>Accessories</b>	Manual, remote control, warranty card, certificate of conformity, Power Cord	
<b>Product structure</b>	Product architect	Hardware shell + lacquer process + aluminum alloy border
	Installation mode	Floor type
	Protective Glass	4 mm toughened glass
	Weight	54kg
	Product size	1848*97*716 (mm)
	Packing size	1960*210*810 (mm)
<b>Operating parameter</b>	Brightness Control	
	Temperature	
	Working Environment	Working Temperature: 0 ° C to + 50 ° C working humidity: 5% to 90%

	Power supply	AC110~240V 60HZ
	Power	80W